

产品规格书

PRODUCT SPECIFICATION

- ◆ 产品名称 (Product Name) : KL817 系列(KL817 Series)
- ◆ 产品型号 (Product Model) : 4PIN 光电晶体管光耦合器
4PIN dip photo transistor photocoupler
- ◆ 版本号 (Version No.) : V1

描述 Description:

- 发光元件+受光元件 (IR+PT)
- 胶体颜色 (Colloid Color):黑色 (Black)
- 发光颜色 (Emission Color):不可见光 (Invisible Light)
- 产品构造 (Product structure):对照式 (Face to face)

研发中心 R&D Center		客户 Customer	
制作 Prepared by	批准 Approved by	确认 Confirmed by	批准 Approved by
客户名称 (Customer) :			
客户部品号 (Customer No.) :			
发行日期 (Issue Date) : 2023-05-16			
地址: 苏州张家港市杨舍镇国泰北路东侧 Add: East Side of Guotai North Road, Yangshe Town, Zhangjiagang City, Suzhou			
电话(Tel): 0512-35010333		传真(Fax): 0512-35010333	
网址(Web): www.jt-led.com			

1. 产品特点 Product features

- 电流转换率(Current transfer ratio)
CTR: 50~600% at $I_F = 5\text{mA}$, $V_{CE} = 5\text{V}$
- 输入与输出高隔离电压(Viso=5000 V rms)
High isolation voltage between inputs and output (Viso=5000 V rms)
- tr/tf 响应时间(在 $V_{CE}=2\text{V}$ 时, $I_C=2\text{mA}$, $R_L=100\Omega$, t_r Typ.4us、 t_f Typ.3us)
Response time(t_r Typ.4 μs 、 t_f Typ.3 μs at $V_{CE} = 2\text{V}$, $I_C = 2\text{mA}$, $R_L = 100\Omega$)
- 工作温度可达+100°C
Operating temperature up to +110°C
- 4PIN 引脚封装模式
4PIN DIP encapsulation mode
- 无 Pb 且符合 ROHS 标准
Pb free and RoHS compliant
- 静电放电:人体模式 8000V、机器模式 2000V
ESD pass HBM 8000V/MM2000V
- 安全审批 Safety approval (*认证中 In the certification)
UL 1577
VDE DIN EN60747-5-5 (VDE 0884-5)
Nordic Safety (FIMKO/NEMKO/SEMKO/DEMKO)

2. 产品描述 Product Description

- KL817 光耦合器由一块砷化镓发射器和一块 NPN 晶体管组成
KL817 photo coupler consist of one piece of GaAs emitter and one piece of NPN transistor
- 它们采用 4 引脚 DIP 封装, 并提供宽引线间距和 SMD 选项
Packaged in a 4-pin DIP package and available in wide-lead spacing and SMD option

3. 产品应用 Product Applications

- 电流表、计算机 Ammeter、Computer
- 开关电源 Switching power supply
- 仪器应用、测量仪器 Instrumental application、measuring instruments
- 家用电器, 如风扇加热器等 Home appliances, such as fan heaters, etc.
- 电信设备 Telecommunication equipments
- 复印机、自动化设备 Copiers, automation equipment

4. 功能图 Functional Diagram

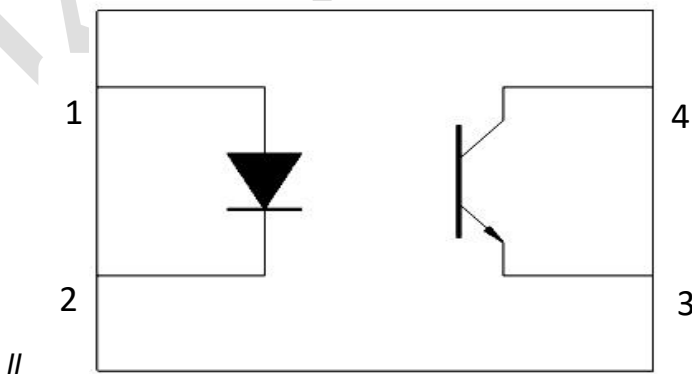

引脚配置 Pin Configuration

1. 阳极 Anode
2. 阴极 Cathode
3. 发射极 Emitter
4. 集电极 Collector

//

5. 光电特性 Electrical-Optical characteristics

- 最大限度额定值(温度=25±5°C) Absolute Maximum Ratings(Ta=25°C)

参数 Parameter		符号 Symbol	额定值 Rated Value	单位 Unit
输入 Input	正向电流 Forward current	I _F	60	mA
	峰值正向电流(100us 脉冲,100Hz 频率) Peak forward current (100us pulse,100Hz frequency)	I _{FP}	1	A
	反向电压 Reverse voltage	V _R	6	V
	输入功率 Input Power	P _I	90	mW
输出 Output	集电极电流 Collector current	I _C	50	mA
	集电极与发射极间电压 Collector and emitter Voltage	V _{CEO}	80	V
	发射极与集电极间电压 Emitter and Collector Voltage	V _{ECO}	6	V
	输出功率 Output Power	P _O	150	mW
总消耗功率 Total Consume Power		P _{TOT}	200	mW
隔离电压 (1*) Isolation Voltage		V _{iso}	5000	Vrms
工作温度 Operating temperature		T _{OPR}	-55 to +110	°C
储存温度 Storage temperature		T _{STG}	-55 to +125	°C
焊接温度 (2*) Soldering temperature		T _{SOL}	260	°C

1* 1 个交流电源 1 分钟内, 相对湿度在 40~60%环境下, 隔离电压测试方法如下

Within 1 minute of 1 AC power supply, the relative humidity is in 40~60% environment, and the isolation voltage test method is as follows

a. 引脚 1&2 短接在一起, 引脚 3&4 短接在一起

Pins 1 & 2 are short together and pins 3 & 4 are connected together

b. 采用带有零电路的隔离耐压测试仪

Use an isolated pressure withstand tester with a zero circuit

c. 施加电压波形应为正弦波

The applied voltage waveform shall be a sine wave

2* 焊接时间为 10 秒 Soldering time is 10 seconds

6. 电气特性 (Ta=25°C, 除非另有规定)

Electrical Characteristics (Ta=25°C unless specified otherwise)

参数 Parameter		符号 Symbol	最小值 Min.	规格值 Typ.	最大值 Max.	单位 Unit	条件 Condition
输入 In put	正向电压 Forward voltage	V _F	-	1.2	1.4	V	I _F =20mA
	反向电流 Reverse current	I _R	-	-	10	μA	V _R =4V
	输入电容 Input capacitance	C _{in}	-	30	250	pF	V=0, f=1kHz
输出 Out put	集电极与发射极间暗电流 Collector-Emitter dark current	I _{CEO}	-	-	100	nA	V _{CE} =20V I _F =0mA
	集电极与发射极间击穿电压 Collector-Emitter breakdown voltage	BV _{CEO}	80	-	-	V	I _C =0.1mA I _F =0mA
	发射极与集电极间击穿电压 Emitter-Collector breakdown voltage	BV _{ECO}	6	-	-	V	I _E =0.1mA I _F =0mA
传输特性 Transfer Characteristics	集电极与发射极间饱和电压 Collector-Emitter saturation voltage	V _{CE(sat)}	-	0.1	0.2	V	I _F =20mA I _C =1mA
	电流传输比 Current transfer ratio(1*)	CTR	50	-	600	%	I _F =5mA V _{CE} =5V
	集电极电流 Collector Current	I _C	2.5	-	30	mA	I _F =5mA V _{CE} =5V
	隔离电阻 Isolation resistance	R _{ISO}	5×10 ¹⁰	1×10 ¹²	-	Ω	V _{IO} =500Vdc 40~60% R.H.
	浮动电容 Floating capacitance	C _f	-	0.6	1.0	pF	V _{IO} =0, f=1MHz
	截止频率 Cut-off frequency	f _c	-	80	-	kHz	V _{CE} =5V, I _C =2mA R _L =100, -3dB
	上升时间 Rise time	t _r	-	4	18	μs	V _{CE} =2V, I _C =2mA, R _L =100Ω
下降时间 Fall time	t _f	-	3	18	μs		

1* 当前转换比率=I_C/I_F*100%, CTR 公差:±3%Current Conversion Ratio = I_C / I_F × 100% , CTR Tolerance:±3%.

- 传输特性等级表(Ta=25°C, 除非另有规定)

Transfer Characteristics level table (Ta=25°C unless specified otherwise)

参数 Parameter		符号 Symbol	最小值 Min.	规格值 Typ.*	最大值 Max.	单位 Unit	条件 Condition
电流传输比 Current Transferratio	KL817	CTR	50	-	600	%	IF=5mA VCE=5V
	KL817L		50	-	100		
	KL817A		80	-	160		
	KL817B		130	-	260		
	KL817C		200	-	400		
	KL817D		300	-	600		
	KL817X		100	-	200		
	KL817Y		150	-	300		

7. 可靠性试验 Reliability Test

序号 NO.	试验项目 Test Items	参考标准 Reference	试验条件 Test conditions	试验过程 Test process	试验数 Qty.(pcs)	允收水准 LTPD
1	温度循环 TC	JESD22-A104C	H:125°C 15min ∫ 5min L:-55°C 15min	300cycle	77	0/77
2	高温操作寿命 HTOL	JESD22-A108C	HTOL@110°C IF=10mA Vce=10V	168、500、1000hrs	77	0/77
3	高温反向偏压 HTRB	JESD22-A108C	HTRB@125°C Vce=60V	168、500、1000hrs	77	0/77
4	温湿度反向偏压寿命试验 H3TRB	JESD22-A101-B	H3TRB@ 85°C、 85%RH Vce=60V	168、500、1000hrs	77	0/77
5	压力锅 Autoclave	JESD22-A102-C	Ta=121°C, 100%RH, 2atm	96hrs	77	0/77
6	高温储存 HTS	JESD22-A103C	HTS@125°C	168、500、1000hrs	77	0/77
7	低温储存 LTS	JESD22-A119	LTS@-55°C	168、500、1000hrs	77	0/77
8	耐锡热试验 RSH	JESD22-B106C	RSH@260±5°C	10sec*3times	22	0/22
9	可焊性 SD	JESD22-B102D	Pb-free@ 245±5°C	3sec*1times	22	0/22
备注 Remarks	以上试验项目如与客户试验要求存在差异或者特殊客户特殊要求的,可根据实际情况按照客户的要求进行试作,客户未要求依我司试验标准试作,不同产品使用不同电流进行测试 All the tests should be performed according to customers' actual requirements, while difference of test standard or special requirements exist. Otherwise, all the tests are performed according to the standard listed above. Different current is applied to the tests of different product models					

8. 特性曲线 Characteristic Curves

图1. 正向电流与环境温度关系



图2. 正向电流与正向电压的关系



图3. 电流传输比与正向电流

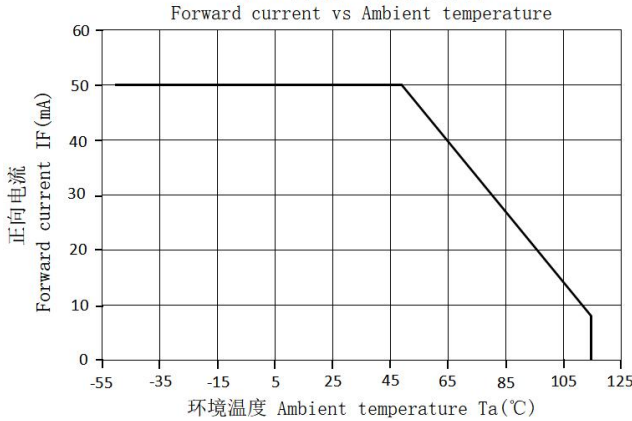

图4. 集电极电流与集电极-发射极电压

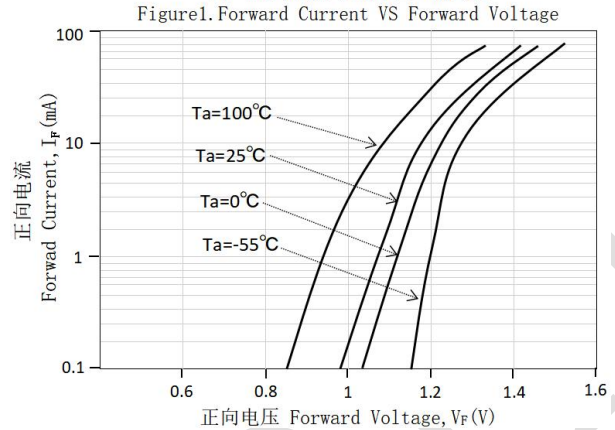

图5. 集电极电流与环境温度关系

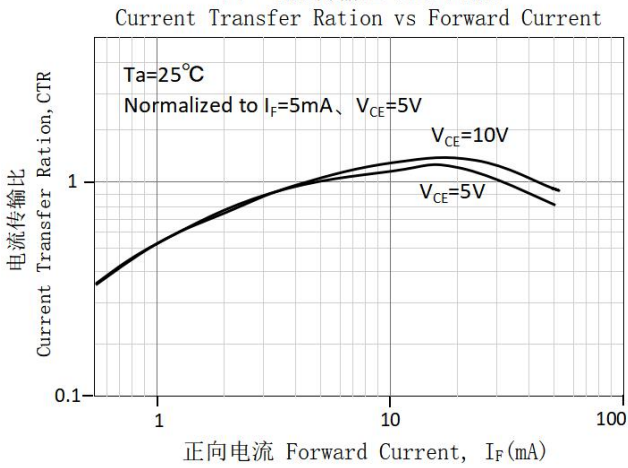

图6. 集电极暗电流与环境温度的关系

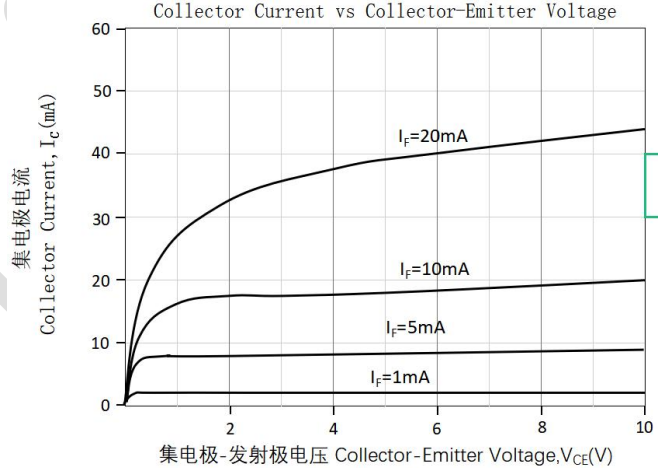

图7. 集电极-发射极饱和电压与环境温度关系
Collector-Emitter Saturation Voltage vs Ambient Temperature

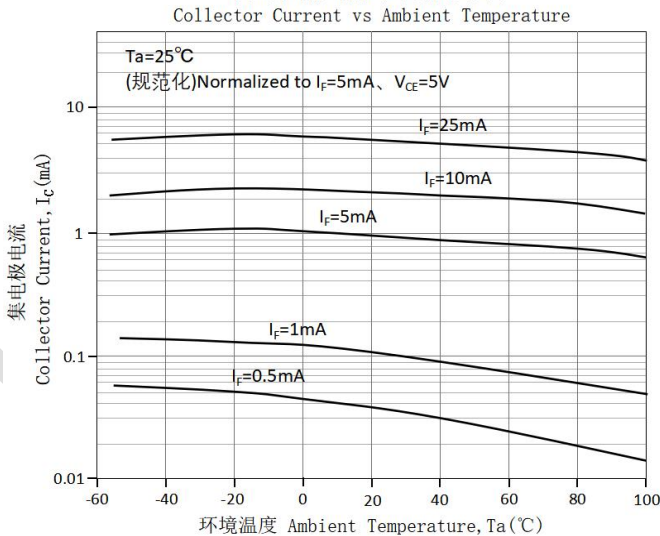

图8. 开关时间与负载电阻的关系
Switching Time vs Load Resistance

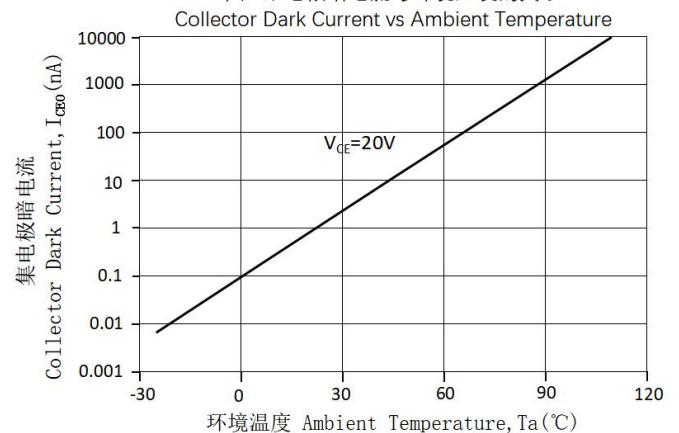

图9. 开关时间测试电路与波形
Switching Time Test Circuit vs Waveforms

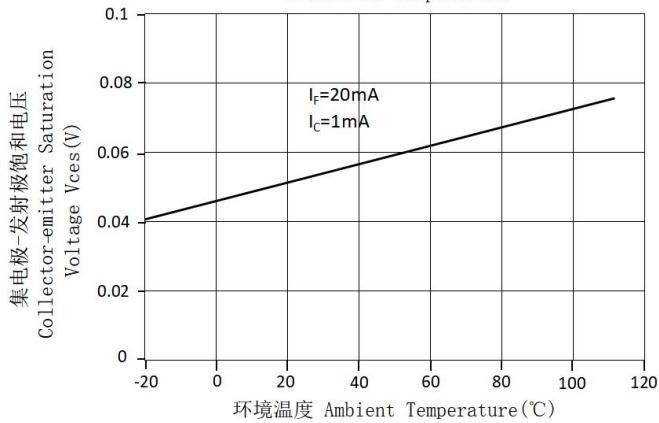

9. 订单信息 Order Information

- 零件编号 Part Number

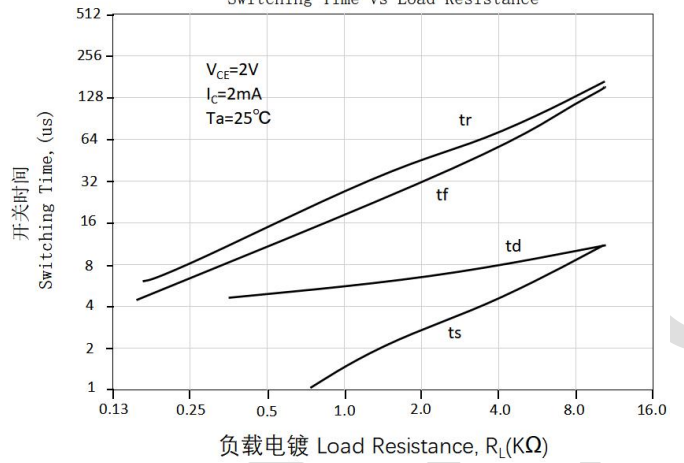
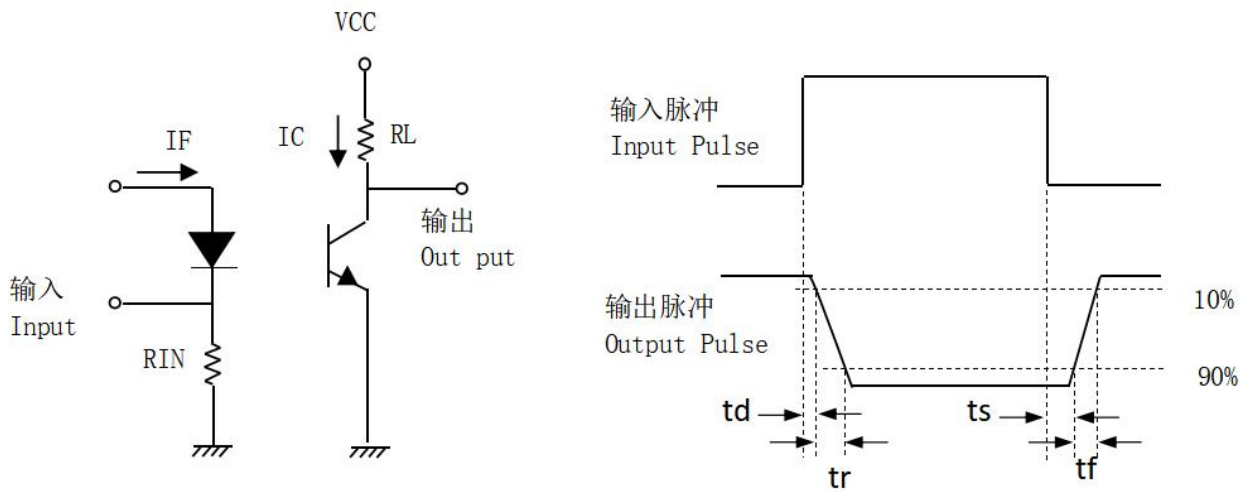
KL817X(Y)(Z)(WS-1)-FV**Notes**

- X 表示引脚形式选项(S、S1、M 或无)
Lead form option (S, S1, M or none)
- Y 表示 CTR 等级(L、A、B、C、D、X、Y 或无)
CTR Rank (A, B, C, D, X, Y, I, J, K, P or none)
- Z 表示料带和卷盘选项(TA, TB, TU, TD 或 无)
Tape and reel option (TA, TB, TU, TD or none)
- WS-1 表示客户代码 Customer code
- F 表示支架框架选项(F:铁、无:铜)
Lead frame option (F: Iron, None: copper)
- V 表示德国安规(可选) VDE (optional)

选项 Option	描述 Description	包装数量 Packing quantity
直脚 None	标准 DIP-4 Standard DIP-4	每管 100pcs 100 units per tube
M	折弯脚(0.4 英寸间距) Wide lead bend (0.4 inch spacing)	每管 100pcs 100 units per tube
S (TA)	表面贴装脚型方式+ TA 料带 & 卷轴选择 Surface mount lead form + TA tape & reel option	每卷 1000pcs 1000 units per reel
S (TB)	表面贴装脚型方式+ TB 料带 & 卷轴选择 Surface mount lead form + TB tape & reel option	每卷 1000pcs 1000 units per reel
S1 (TA)	表面贴装脚型方式(低轮廓)+ TA 料带 & 卷轴选择 Surface mount lead form (low profile) + TA tape & reel option	每卷 1000pcs 1000 units per reel
S1 (TB)	表面贴装脚型方式(低轮廓)+ TB 料带 & 卷轴选择 Surface mount lead form (low profile) + TB tape & reel option	每卷 1000pcs 1000 units per reel
S (TU)	表面贴装脚型方式+ TU 料带 & 卷轴选择 Surface mount lead form + TU tape & reel option	每卷 1500pcs 1500 units per reel
S (TD)	表面贴装脚型方式+ TD 料带 & 卷轴选择 Surface mount lead form + TD tape & reel option	每卷 1500pcs 1500 units per reel
S1 (TU)	表面贴装脚型方式(低轮廓)+ TU 料带 & 卷轴选择 Surface mount lead form (low profile) + TU tape & reel option	每卷 1500pcs 1500 units per reel
S1 (TD)	表面贴装脚型方式(低轮廓)+ TD 料带 & 卷轴选择 Surface mount lead form (low profile) + TD tape & reel option	每卷 1500pcs 1500 units per reel

10. 封装尺寸(单位:毫米) Package Drawing(Unit:mm)

- 标准 DIP 型号 Standard DIP Type

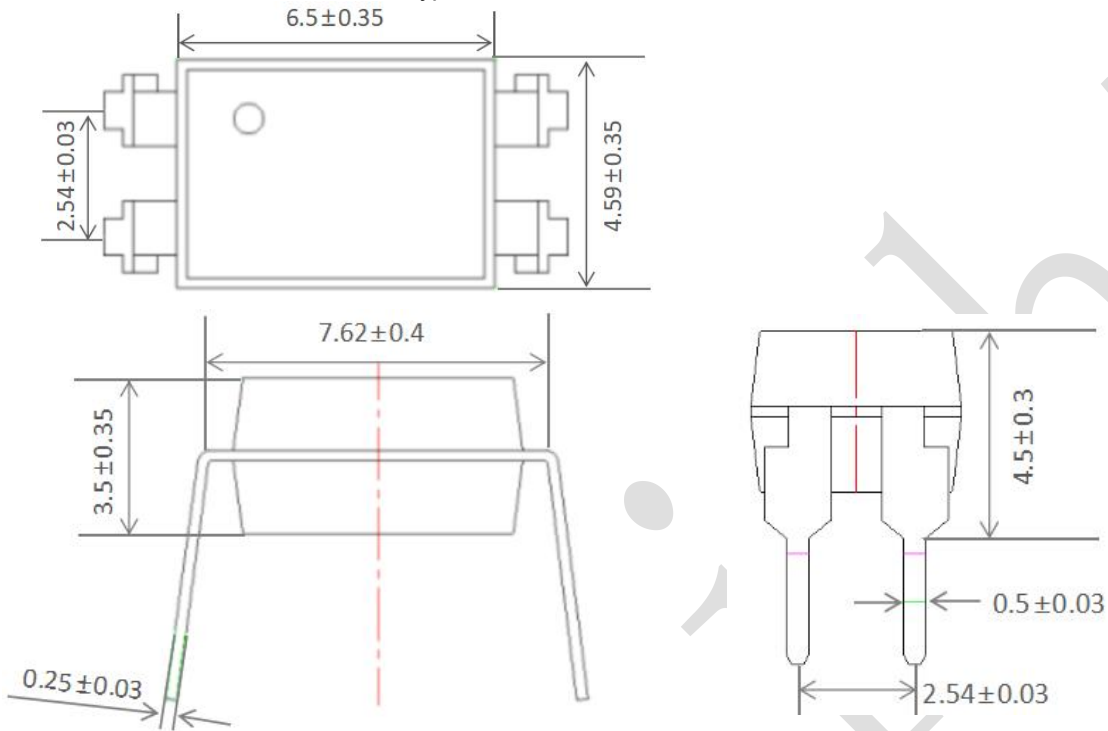

- 选项 M 型号 Option M Type

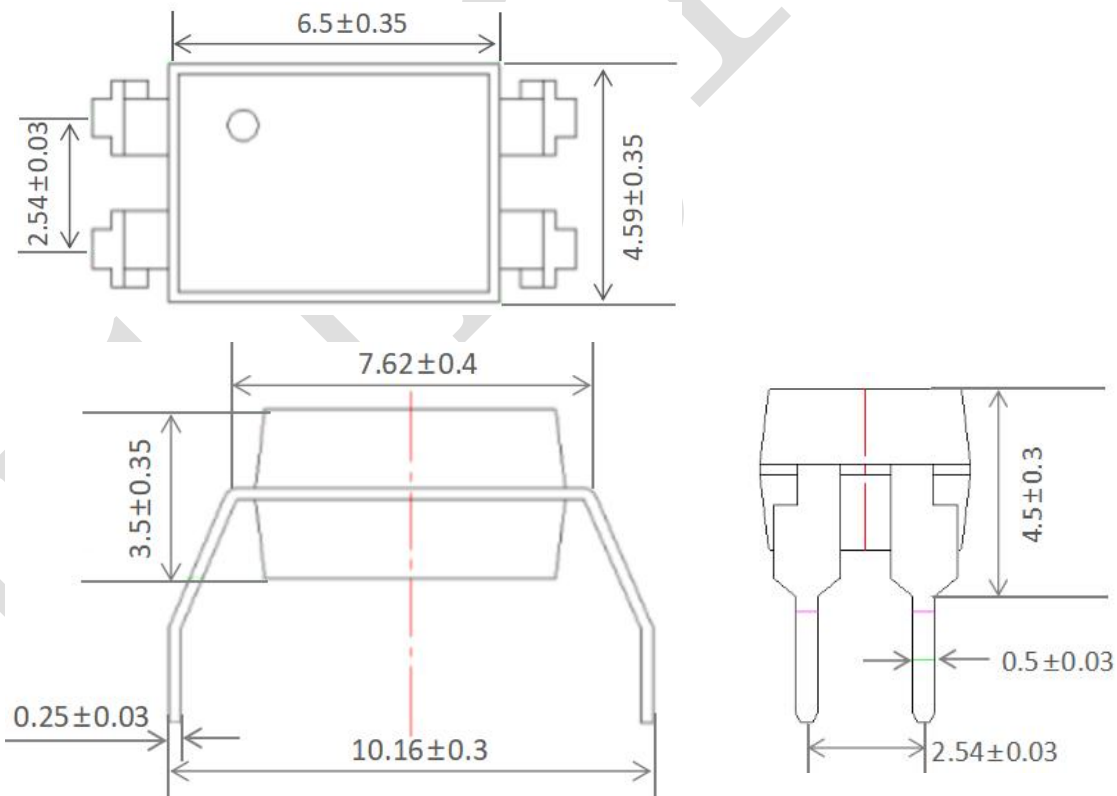

• 选项 S 型号 Option S Type

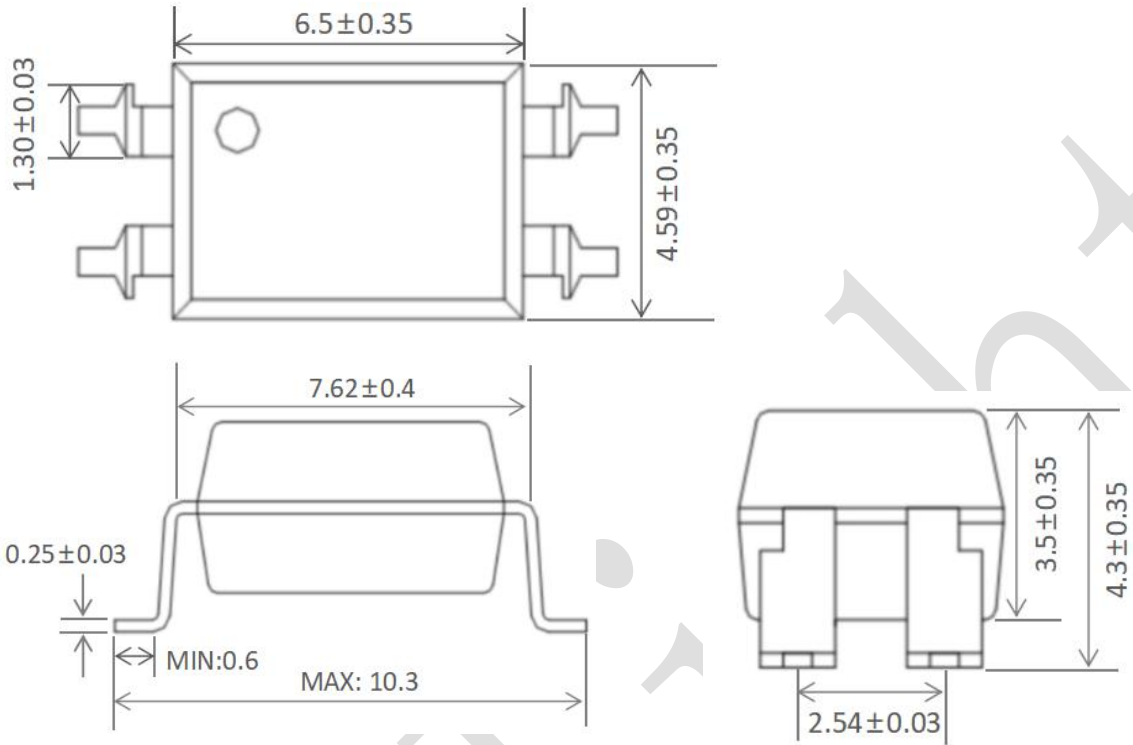

• 选项 S1 型号 Option S1 Type

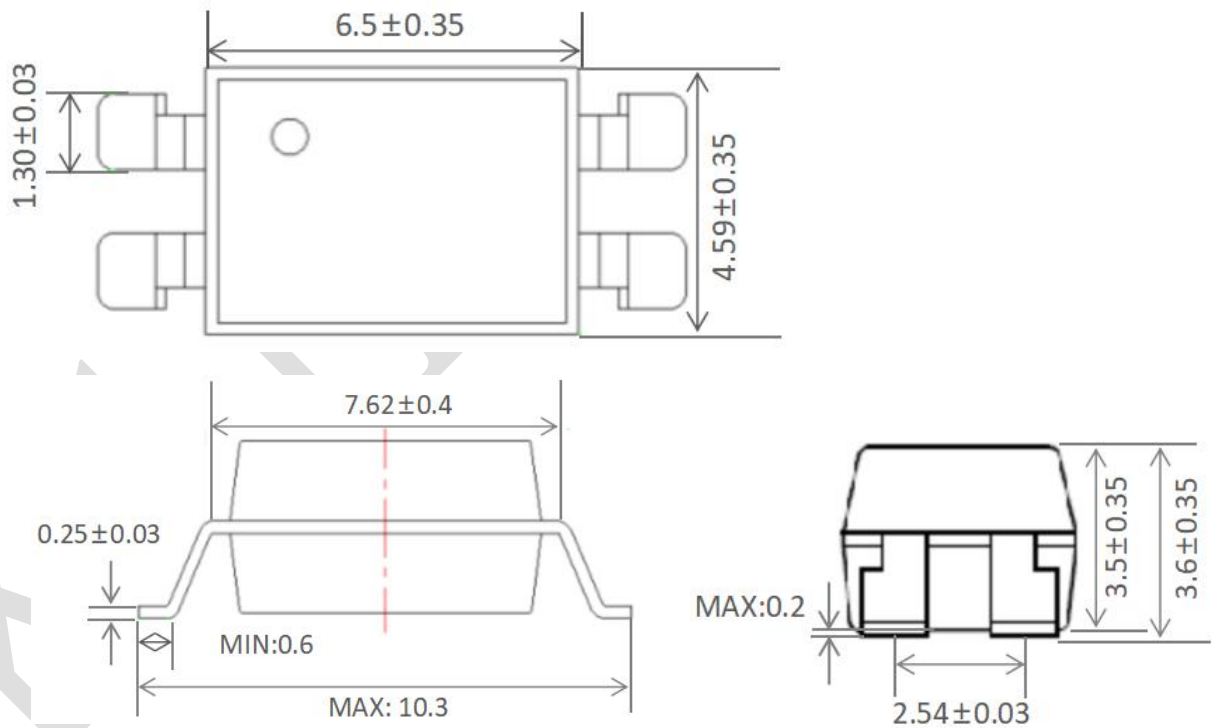

- 选项 S2 型号 Option S2 Type

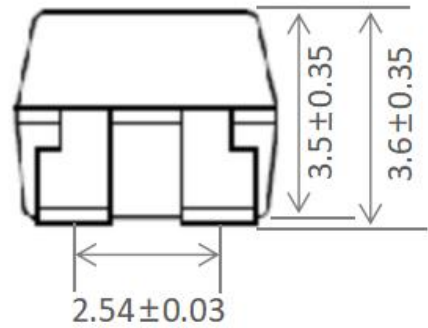
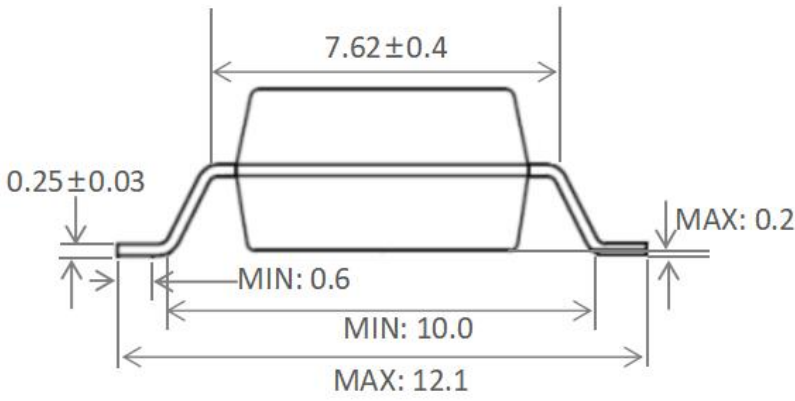
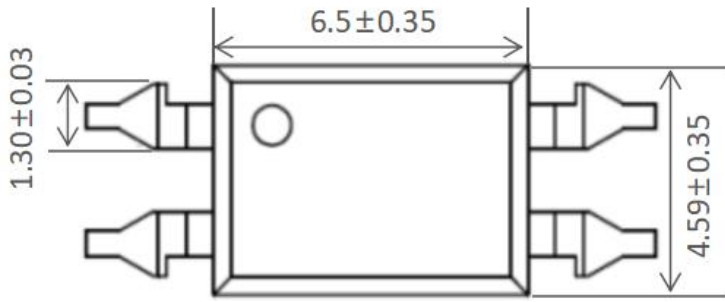

S 和 S1 脚型选项
The S and S1 foot-type options

S2 脚型选项
The S2 foot-type options

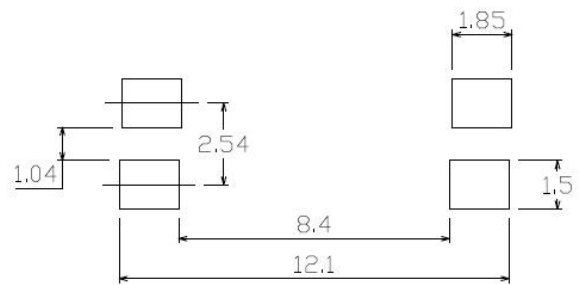
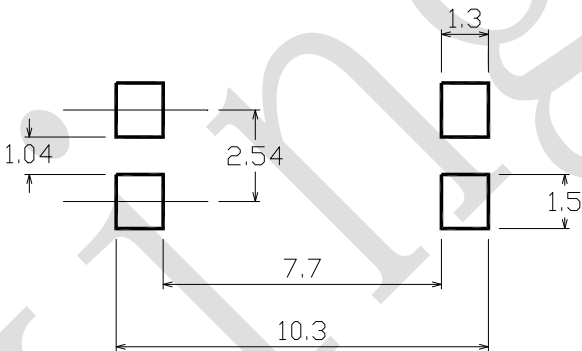

11. 设备标记 Device marking**注意 Notes**

- KL 表示晶台光电有限公司
denotes KingLight
- 817 表示设备部件号
denotes Device Part Number
- R 表示 CTR 等级
denotes CTR Rank
- Y 表示 1 位年份代码
denotes 1 digit Year code
- WW 表示 2 位周别代码
denotes 2 digit Week code
- V 表示 VDE(可选)
denotes VDE (optional)

12. 料带和卷轴包装规格

Tape & Reel Packing Specifications

• 选择 TA Option TA

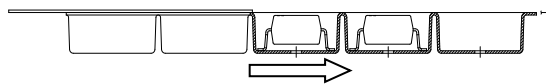
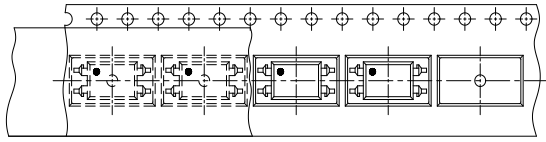

卷轴进给方向 Direction of feed from reel

• 选择 TB Option TB

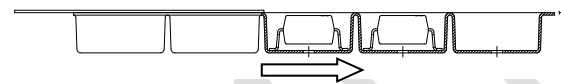
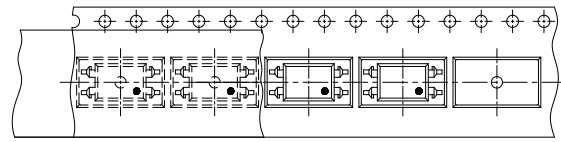

卷轴进给方向 Direction of feed from reel

料带尺寸 Material belt size

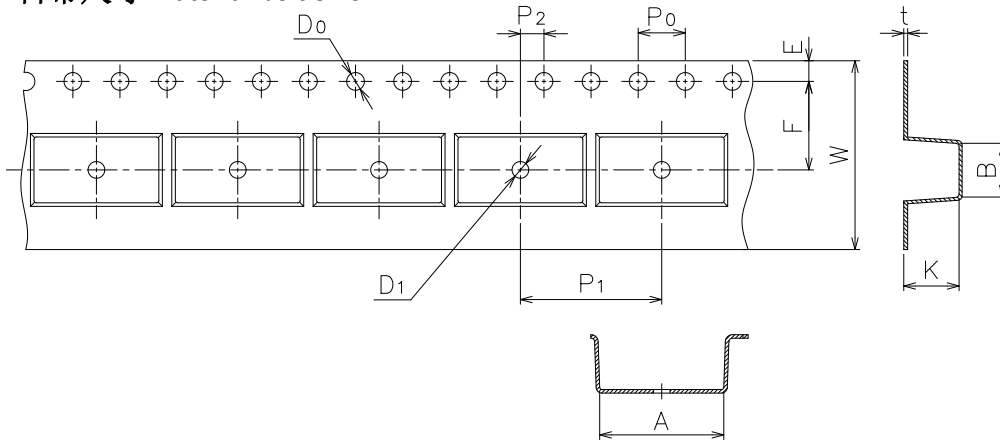

尺寸编号 Dimension No.	A	B	D0	D1	E	F
尺寸(mm) Dimension(mm)	10.4±0.1	4.55±0.1	1.5±0.1	1.5±0.1	1.75±0.1	7.5±0.1
尺寸编号 Dimension No.	P0	P1	P2	t	W	K
尺寸(mm) Dimension(mm)	4.0±0.1	12.0±0.1	2.0±0.1	0.33±0.1	16.0+0.3/-0.1	4.55±0.1

• 选择 TD Option TD

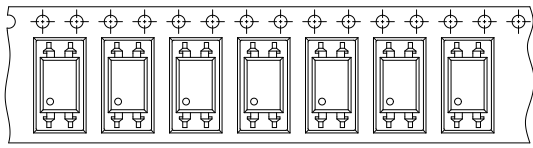

卷轴进给方向 Direction of feed from reel

• 选择 TD Option TU

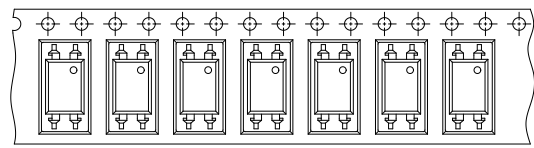

卷轴进给方向 Direction of feed from reel

料带尺寸 Material belt size

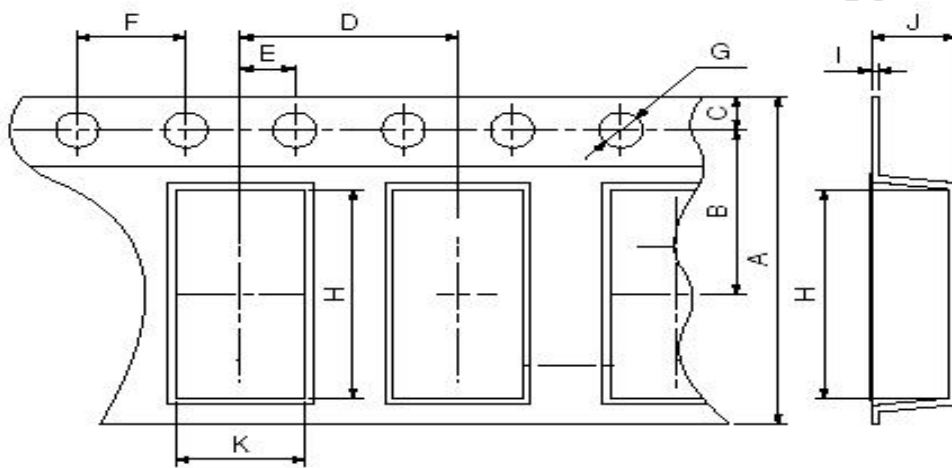

尺寸编号 Dimension No.	A	B	C	D1	E	F
尺寸(mm) Dimension(mm)	16±0.3	7.5±0.1	1.75±0.1	8.0±0.1	2.0±0.1	4.0±0.1
尺寸编号 Dimension No.	G	H	I	J	K	
尺寸(mm) Dimension(mm)	1.5+0.1/-0	10.4±0.1	0.4±0.05	4.55±0.1	5.1±0.1	

13. 焊接温度曲线 Temperature Profile Of Soldering

• 回流焊 Reflow soldering

建议在下面所示的温度和时间分布条件下, 进行一次回流焊作业, 不得超过三次

One time soldering reflow is recommended within the condition of temperature and time profile shown below. Do not solder more than three times.

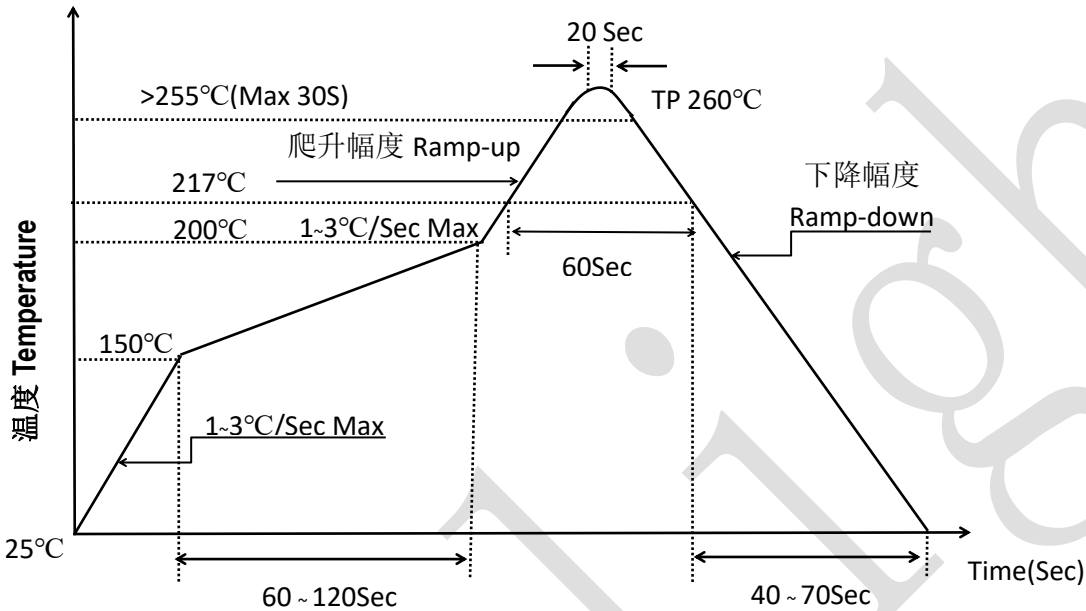

• 波峰焊 Wave Soldering

温度条件下, 建议一次焊接

One time soldering is recommended within the condition of temperature

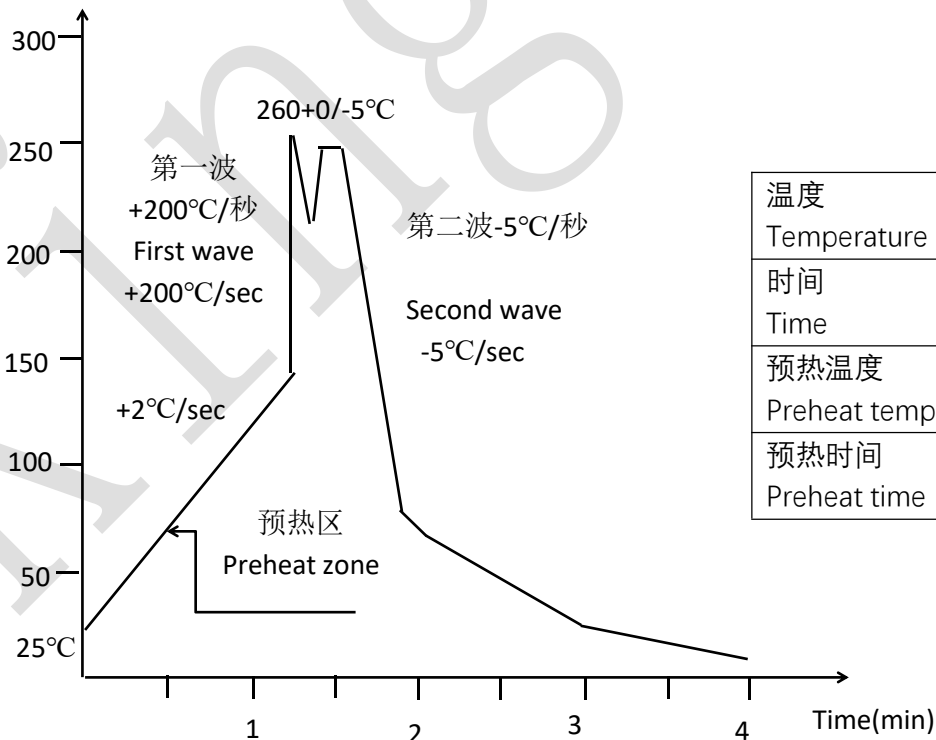

温度 Temperature	260°C+0/-5°C
时间 Time	10秒 10Sec
预热温度 Preheat temperature	25 至 140°C 25 to 140°C
预热时间 Preheat time	30 至 80 秒 30 to 80 Sec

14. 免责声明 Disclaimer

- 本规格书中的规格如有变更，恕不另行通知，本公司保留对上述产品规格变更权力
The specifications in this specification are subject to change without notice, and the Company reserves the right to change the above product specifications
- 使用本产品时，请注意应用参数若超出产品本身最大额定值，造成产品损害，我司概不负责
When using this product, please note that if the application parameters exceed the maximum rating of the product itself, we will not cause the product damage